



NEW

MC405C-5

SPIDER CRANE

Crane Capacity
3.83t × 2.7m

Max. working radius
16m × 0.21t

Max. Lifting Height
16.8m / 20.7m
(with fly jib)

Enhanced Functionality and Superior Safety

Technology In Motion

- Pick & Carry Duties : 500kg
- Crane / Outrigger Interlock System
- Programmable Moment Limiter
- Multi Outrigger Mode
- Digital Feedback Remote Control
- 4 Fall / 2 Fall Hook Block
- EU Stage V Compliant Engine
- Available with Seacher Hooks & Fly jib

With 850kg Searcher Hook (option)



With Fly jib (option)



1.5t Searcher Hook (option)

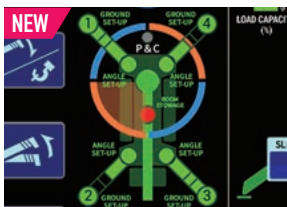

Multi Outrigger Mode



Working Range Setting for Slew Restriction



Proportional Radio Remote Control



Front Camera & LED Light



Electric Motor Power (option)

Specifications

Model		MC405CWM(E)-5
Crane capacity		3.83t x 2.7m
Max. working radius		16m x 0.21t
Max. lifting height (on the ground)		16.8m
Max. lifting height (underground)		-20.5m (4 falls)
Winch system	Hook speed	12.0m/min [18.0m/min] (4 layers, 4 falls)
	Hoist wire rope	IWRC 6 x WS(26) φ8 x 92m
Telescoping system	Type	Fully automatic 5-section pentagonal telescopic boom
	Boom length	4.735m ~ 16.475m
	Boom telescoping stroke / time	11.7m / 54.2sec [41.3sec]
Boom hoist system	Hoist angle / time	0 ~ 80deg / 24.5sec [17.0sec]
Swing system	swing angle / time	360deg / 2.1rpm [2.5rpm]
Outrigger system	Type	Extended Hydraulic cylinder direct acting Setting up Hydraulic cylinder direct acting
	Max. extended width (outer dims)	(Lateral) 6,076mm x (Front) 5,441mm x (Rear) 5,829mm
Travel system	Type	Hydraulic motor driven , stepless speed changer
	Travel speed	0 ~ 2.9km/h
	Gradability	20deg
	Crawler ground length x width	1,715mm x 320mm
Engine	Model	YANMAR 3TNV88F-EPMB
	Displacement	1.642L [1,642cc]
	Rated output	17.4kw/2,400min ⁻¹ [23.6PS/2,400rpm]
	Starting method	Electric starting
	Fuel / Fuel tank capacity	Diesel / 60.0L
Motor (MC405CWME-5)	Motor type	Totally enclosed fan-cooled motor 7.5kw, 3-Phase, 380V
	Starting system	Inverter system (30Hz-60Hz)
Remote control system	Type	Paddle type proportional radio remote controller
	Micro / High speed mode	Available
	Load display for transmitter	Available
Pick & Carry capacity	Outrigger operation	Available
		500kg
Overall length x width x height		4,980mm x 1,380mm x 1,980mm
Machine weight		5,640kg (5,790kg with electric motor)
Safety device	Overwind protection, Load indicator, Hydraulic safety valve, Wire rope latch, Level, Machine body inclination alarm, EMO switch, Travel lock lever, Crane/Outrigger interlock device, Moment limiter, Rotary lamp, Front camera, Slew restriction system, Anti-Interference device	
Options	White rubber track, Single fall hook, Protection roll bar, Searcher hooks (850kg & 1,500kg), Fly jib (520kg)	

Dimensions

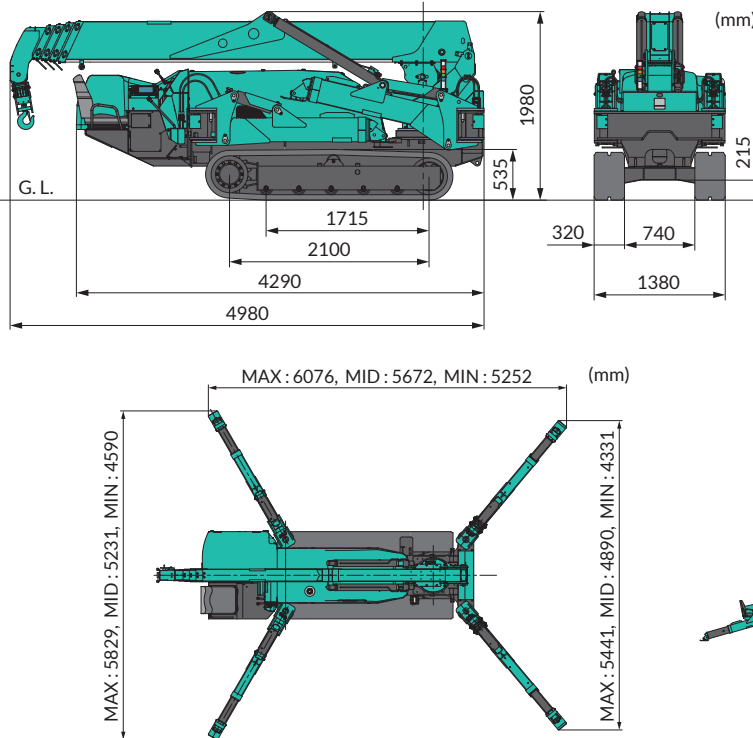

Rated Total Load Chart (4falls)

Outrigger extended to maximum							
4.735m / 7.695m Boom		10.655m Boom		13.565m Boom		16.475m Boom	
Working radius(m)	Rated total load(kg)	Working radius(m)	Rated total load(kg)	Working radius(m)	Rated total load(kg)	Working radius(m)	Rated total load(kg)
2.7 or less	3830	3.5	3030	4.0	2230	5.0	1130
3.5	3030	4.0	2580	4.5	1930	5.5	980
4.0	2580	5.0	2030	5.0	1730	6.0	910
5.0	2030	6.0	1680	6.0	1400	7.0	760
6.0	1680	7.0	1380	7.0	1180	8.0	650
7.0	1380	8.0	1130	8.0	1030	9.0	600
7.25	1330	9.0	880	9.0	930	10.0	550
		10.2	580	10.0	830	11.0	490
				11.0	690	12.0	440
				12.0	530	13.0	380
				13.1	430	14.0	320
						15.0	260
						16.0	210

* The Rated Total Load Chart is based on actual working radius with the bending of boom attributable to load reflected and is shown with the mass of hook (50kg) included.

Fly jib Rated Total Load Chart (Optional)

Boom angle (deg)	Jib length : 4.5m (kg)
76	520
72	520
69	420
66	320
63	250
60	220
55	170

MAX. Reach Below Ground

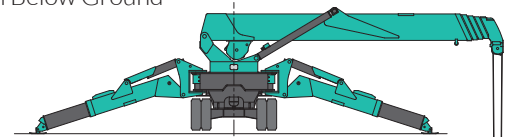

Working Range Chart (4falls)

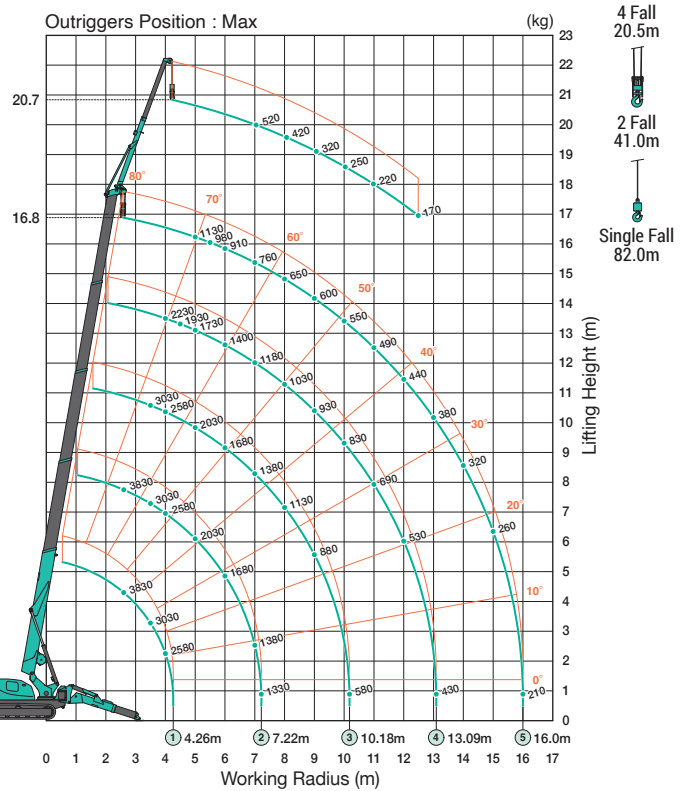

* Due to improvements, the specifications are subject to change without notice.

Before use, please read the Operation Manual

